

1 2 3 4 5 6 7 8

REV	LOCATIONS	DESCRIPTION	DATE	REVISER	APPD
1		Structural and material changes	15/APR/20	KATE	CHERRY

SPECIFICATIONS

Electrical
 Current Rating: 0.5A AC(rms)/DC
 Voltage Rating: 30V AC(rms)/DC
 Contact Resistance: 20 mΩ Max
 Insulation Resistance: 100 MΩ Min
 Withstanding Voltage: 200V AC r.m.s
 Temperature Range-Operating: -40°C~+105°C

Material and Plating
 Housing: LCP (UL 94V-0)
 Contact: Phosphor bronze/ Gold flash or Tin plated
 Solder Tab: Brass/ Gold flash or Tin plated

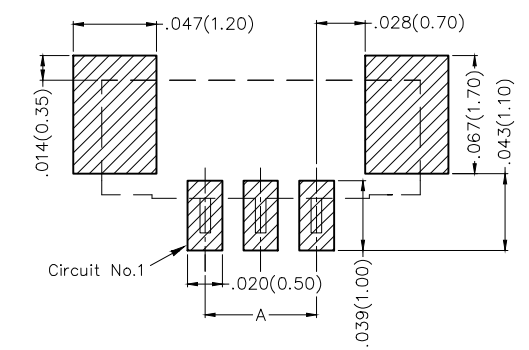
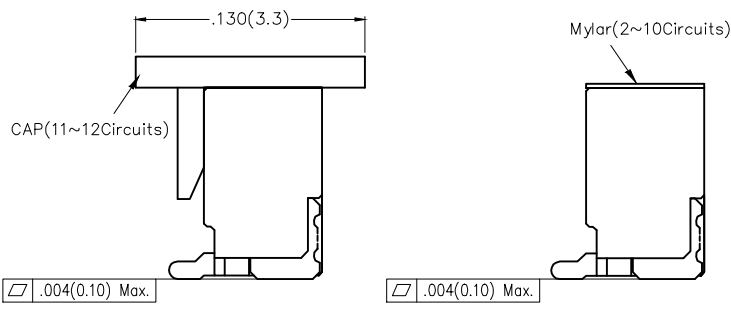
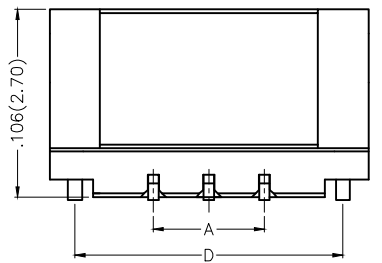
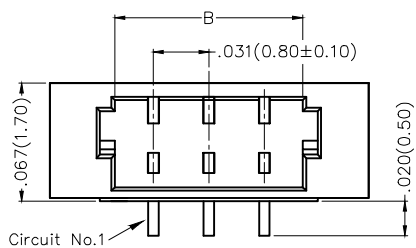
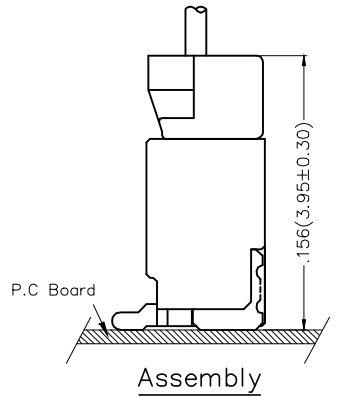
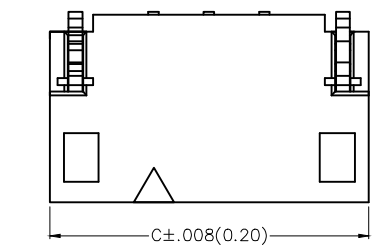

Recommended P.C.Board Layout
 General tolerances: ±.002(0.05)

Ordering Information

FWF 080 01 — S XX S X 3 W5 M
 1 2 3 4 5 6 7 8 9 10

1	Category	2	Series Number	3	Distinction No.	4	Row Option	5	Circuits
	FWF-Wafer		080-Pitch0.8mm		01		S-Single Row		XX
6	Entry Angle	7	Plating	8	Material-Resin	9	Color-Resin	10	Packaging
	S-180° Vertical		1-Gold Plated 2-Tin Plated		3-LCP		W5-Natural		M-Reel

<p>THIRD ANGLE PROJECTION</p>	GENERAL TOLERANCES (UNLESS SPECIFIED)		APPROVE BY	DATE	PART NO.	ITEM NO.	<p>Leader Of Industry</p>
	X.±.012(0.30)	X.±5°	FRANK	28/JUN/13	FWF08001-SXXSX3W5M	FWF08001	
DESIGN UNITS Inch (metric)	X.X±.008(0.20)	.X±2°	CHECKED BY	DATE	TITLE		REV 1
SCALE 5:1	X.XX±.006(0.15)	.XX±1°	JACOB	28/JUN/13	Wire to Board (Wafer) Pitch 0.8mm 180° Vertical (SMT)		SHEET NO. 1/3
SIZE A4	X.XXX±.004(0.10)	.XXX±0.5°	DRAWN BY	DATE	THIS DRAWING CONTAINS INFORMATION THAT IS PROPRIETARY TO TXGA INDUSTRIAL ELECTRONICS(S.Z)CO.,LTD AND SHOULD NOT BE USED WITHOUT WRITTEN PERMISSION		
			CHERRY	28/JUN/13			

1 2 3 4 5 6 7 8

REV	LOCATIONS	DESCRIPTION	DATE	REVISER	APPD

A

A

B

B

C

C

D

D



E

E

F

F

Circuits (n)	Part No.	Dimensions(in/mm)			
		A	B	C	D
2	FWF08001-S02SX3W5M	.031(0.80)	.075(1.90)	.149(3.78)	.120(3.04)
3	FWF08001-S03SX3W5M	.063(1.60)	.106(2.70)	.180(4.58)	.151(3.84)
4	FWF08001-S04SX3W5M	.094(2.40)	.138(3.50)	.212(5.38)	.183(4.64)
5	FWF08001-S05SX3W5M	.126(3.20)	.169(4.30)	.243(6.18)	.214(5.44)
6	FWF08001-S06SX3W5M	.157(4.00)	.201(5.10)	.275(6.98)	.246(6.24)
7	FWF08001-S07SX3W5M	.189(4.80)	.232(5.90)	.306(7.78)	.277(7.04)
8	FWF08001-S08SX3W5M	.220(5.60)	.264(6.70)	.338(8.58)	.309(7.84)
9	FWF08001-S09SX3W5M	.252(6.40)	.295(7.50)	.369(9.38)	.340(8.64)
10	FWF08001-S10SX3W5M	.283(7.20)	.327(8.30)	.401(10.18)	.372(9.44)
12	FWF08001-S12SX3W5M	.346(8.80)	.390(9.90)	.464(11.78)	.435(11.04)
16	FWF08001-S16SX3W5M	.472(12.00)	.516(13.10)	.590(14.98)	.561(14.24)
20	FWF08001-S20SX3W5M	.598(15.20)	.642(16.30)	.716(18.18)	.687(17.44)

 THIRD ANGLE PROJECTION	GENERAL TOLERANCES (UNLESS SPECIFIED)		APPROVE BY FRANK	DATE 28/JUN/13	PART NO. FWF08001-SXXSX3W5M	ITEM NO. FWF08001	 Leader Of Industry
	X.±.012(0.30)	X.±5'	CHECKED BY JACOB	DATE 28/JUN/13	TITLE Wire to Board (Wafer) Pitch 0.8mm 180° Vertical (SMT)		
	X.X±.008(0.20)	.X'±2'	DRAWN BY CHERRY	DATE 28/JUN/13	REV 1	SHEET NO. 2/3	
	X.XX±.006(0.15)	.XX'±1'	THIS DRAWING CONTAINS INFORMATION THAT IS PROPRIETARY TO TXGA INDUSTRIAL ELECTRONICS(S.Z)CO.,LTD AND SHOULD NOT BE USED WITHOUT WRITTEN PERMISSION				
SCALE 5:1	SIZE A4	X.XXX±.004(0.10)	.XXX±0.5'				

1 2 3 4 5 6 7 8

REV	LOCATIONS	DESCRIPTION	DATE	REVISER	APPD

Note:

- 10 sprocket hole cumulative tolerance ± 0.2
- Carrier camber is within 1.0mm in 250mm
- Material: White Conductive polystyrene Alloy 100% recyclable
- All dimensions meet EIA-481-3 requirements
- Peel off force of cover tape & carrier tape: 20g~130g(0.2N~1.3N)
- Component load per 13" reel: 2,000 pcs

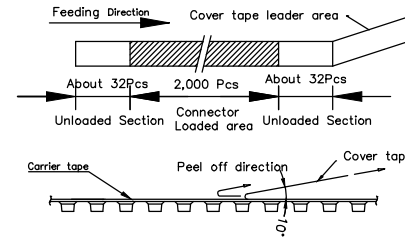
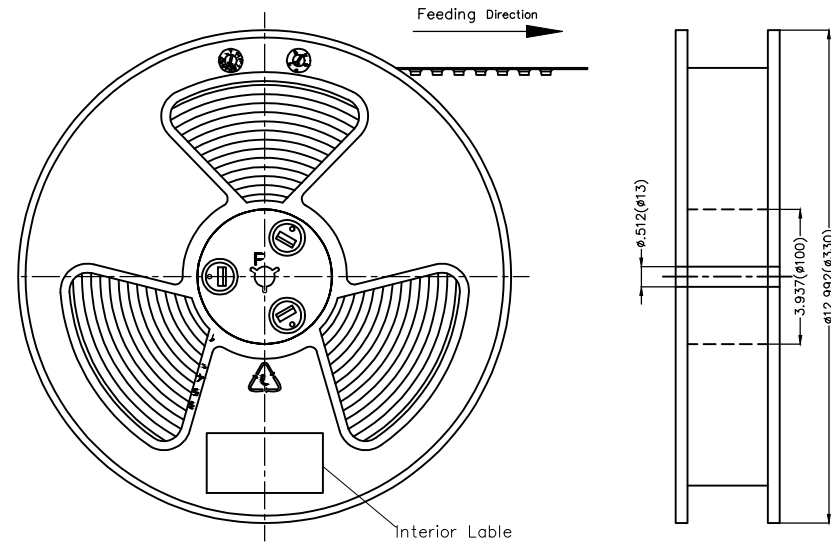

Circuits (n)	Dimensions(in./mm)		Circuits (n)	Dimensions(in./mm)	
	D	W		D	W
2	.295(7.50)	.630(16.00)	8	.295(7.50)	.630(16.00)
3	.295(7.50)	.630(16.00)	9	.295(7.50)	.630(16.00)
4	.295(7.50)	.630(16.00)	10	.453(11.50)	.945(24.00)
5	.295(7.50)	.630(16.00)	12	.453(11.50)	.945(24.00)
6	.295(7.50)	.630(16.00)	16	.453(11.50)	.945(24.00)
7	.295(7.50)	.630(16.00)	20	.453(11.50)	.945(24.00)

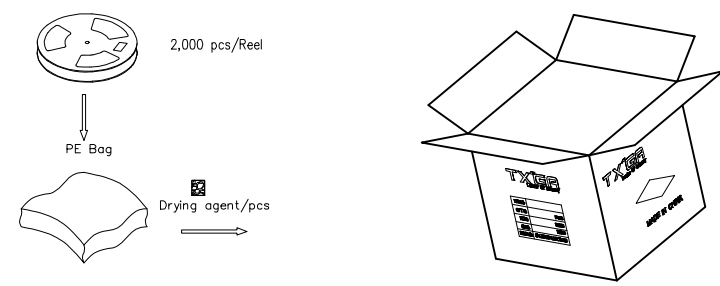
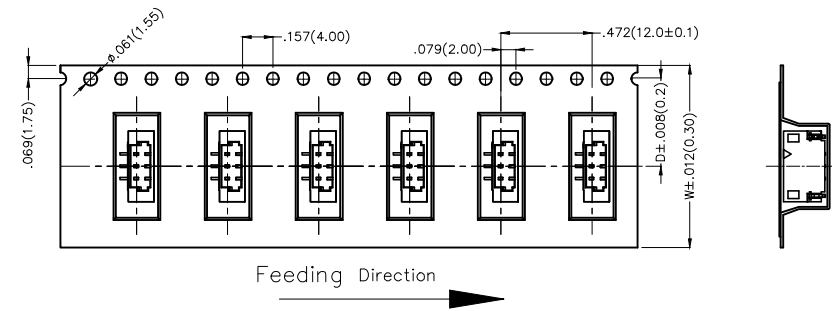

 THIRD ANGLE PROJECTION	GENERAL TOLERANCES (UNLESS SPECIFIED)		APPROVE BY	DATE	PART NO.	ITEM NO.	 Leader Of Industry	
	X.±.012(0.30)	X.±5'	FRANK	28/JUN/13	FWF08001-SXXSX3W5M	FWF08001		
	DESIGN UNITS	X.X±.008(0.20)	.X'±2'	CHECKED BY	DATE	TITLE		REV 1 SHEET NO. 3/3
	Inch (metric)	X.XX±.006(0.15)	.XX'±1'	JACOB	28/JUN/13	Wire to Board (Wafer) Pitch 0.8mm 180° Vertical (SMT)		
SCALE	SIZE	X.XXX±.004(0.10)	.XXX'±0.5'	DRAWN BY	DATE	THIS DRAWING CONTAINS INFORMATION THAT IS PROPRIETARY TO TXGA INDUSTRIAL ELECTRONICS(S.Z)CO.,LTD AND SHOULD NOT BE USED WITHOUT WRITTEN PERMISSION		
5:1	A4			CHERRY	28/JUN/13			